

R-Series Profibus

Temposonics RP and RH
Measuring length 25 - 7600 mm



Advanced Communication
... offers Multi-Position Measurement

New: Diagnostic LED



- Rugged Industrial Sensor
- Linear and Absolute Measurement
- LEDs for Sensor Diagnostics
- Contactless Sensing with Highest Durability
- Superior Accuracy: Linearity better 0,01 %
- Resolution 5 µm
- Repeatability 0,001 %
- Direct Profibus-DP Output, Displacement + Speed
- Multi-Position Measurement: 1 Sensor for max. 15 Positions

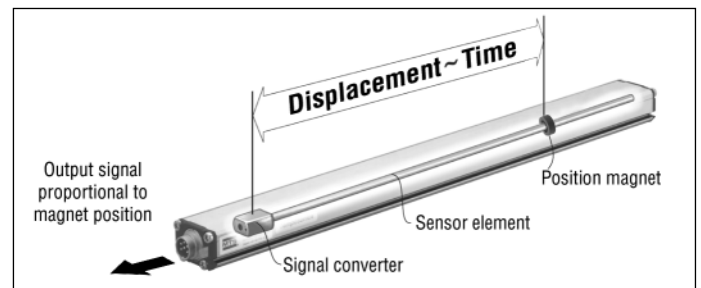

Magnetostriction

The absolute **Temposonics®** linear position sensors are based on the MTS developed magnetostrictive measurement principle. That combines various magneto-mechanical effects and uses the physical height precise speed-measurement of an ultrasonic wave (torsion pulse in its sensor element) for position detecting. Sensor integrated signal processing transforms the measurements directly into market standard outputs. The contactless principle - an external movable magnet marks the position - eliminates the wear, noise and erroneous signal problems and guarantees the best durability without any recalibration.

Form factor

The extremely robust sensor, ideal for continuous operation under harshest industrial conditions is completely modular in mechanic and electronic design.

- A profile or rod-shaped sensor housing protects the sensing element in which gives rise to the measurement signal.
- The sensor head accommodates the complete modular electronic interface with active signal conditioning. Double encapsulation ensures high operating safety and optimum EMC protection.
- The position transmitter, a permanent magnet - fixed at the mobile machine part - drives contactlessly over the sensor's stroke and starts measuring through the housing wall.

New...a sensor diagnostic display

Integrated LEDs (green/red) provide basic visual feedback for normal sensor operation and troubleshooting.



Green	Red	Description
ON	OFF	Normal function
ON	ON	Magnet not detected or Wrong quantity of magnets
Flashing	OFF	Waiting for Master parameters
Flashing	ON	Programming mode

Profibus Interface

Temposonics sensors fulfill all requirements of PROFIBUS-DP (EN 50170). The sensor realizes the absolute position measuring with direct transmission of serial, bitsynchronous data in RS485 standard to control units in a baud rate of 12 Mbit/s maximum. PROFIBUS interface is built-up with Siemens buscontroller SPC3. In addition to applications data transmission, PROFIBUS provides powerful functions for diagnostics and configuration, loaded into the bus via the GSD (Electronic Device Data Sheet). Profibus sensors - corresponding DP-slave Class 2 - featuring

Sensor outputs:

- Absolute position measurement
- Speed measurement
- Sensor status
- Error detection (e.g. magnet status)

Selectable parameters:

- Offset/Preset for each magnet
- Measuring direction: Forward/reverse
- Resolution
- Different data formats

Operation modes

PROFIBUS sensors provide measurements with one or multiple magnets. Following different operation modes are available:

- **Standard measurement:** Position measurement 1 magnet
- **Multi-Magnets measurement:** Position measurement of max. 15 magnets simultaneously resp. position and speed of max. 5 magnets.

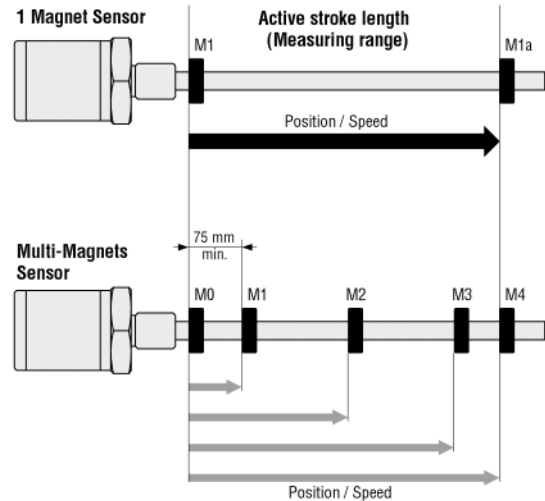

Data exchange

With Multi-Magnet measurement, 1 status byte and 3 bytes of position data for each position are transmitted. The status byte contains e.g. the error bit and the position number of the following measurement value. Dependent on sensor parameters setting, the position data can be transferred to the control unit in different formats (e.g. INTEL or MOTOROLA format).

Accessory: MTS Servicetool

Profibus Address-Programmer is used for setup sensor's slave address. Normally addressing is done by Profibus **SetSlaveAddress**. Since some master systems do not support this standard, or customers controller can not handle, this tool - connected to the sensor - can be used for direct addressing.

Technical Data

Input	
Measured variable	Displacement / Option: Multi-Magnets measurement (max. 15 positions or 5 positions + 5 velocities)
Measuring length	Profile 25 - 5000 mm / Rod 25 - 7600 mm
Output	
Output signal	PROFIBUS-DP System according ISO 74498
Data format	PROFIBUS-DP (EN 50 170)
Data transmission rate	Max. 12 Mbit/s
Accuracy	
Resolution	
- Displacement	5 µm / other values selectable via GSD-File
- Speed	5 mm/s µm displacement resolution : 0,64 mm/s up to 500 / 0,43 mm/s up to 2000 / 0,21 mm/s up to 4500 / 0,14 mm/s up to 7600 mm stroke length
Linearity	< ± 0,01 % F.S. (Minimum ± 50 µm)
Repeatability	< ± 0,001 % F.S. (Minimum ± 2,5 µm)
Cycle time, standard (1 magnet)	0,5 ms at 500 mm / 1 ms at 2000 mm / 2 ms at 4500 mm / 3,1 ms at 7600 mm stroke length each additional magnet + 0,05 ms; for speed measurement ca. + 0,03 ms
Temperature coefficient	<15 ppm/° C
Hysteresis	< 4 µm
Operating conditions	
Magnet speed	any
Operating temperature	-40 °C ... +75 °C
Dew point, humidity	90% rel. humidity, no condensation
Protection	Profile: IP65, Rod: IP67, if mating connector is correctly fitted
Shock test	100 g single hit, IEC-Standard 68-2-27
Vibration test	15g / 10 - 2000 Hz, IEC-Standard 68-2-6
Standards, EMC test	Electromagnetic emission EN 50081-1 Electromagnetic immunity EN 50082-2 EN 61000-4-2/3/4/6, Level 3/4, Criterium A, CE-qualified
Form factor, material	
Diagnostic display	LEDs beside connector
<u>Profile model:</u>	
Sensor head	Aluminum
Sensor stroke	Aluminum
Position magnet	Magnet slider or removable U-magnet
<u>Rod model:</u>	
Sensor head	Aluminum
Rod with flange	Stainless steel 1.4301 / AISI 304
-Pressure rating	350 bar, 700 bar peak
Position magnet	Ring magnets, U-magnets
Installation	
Mounting position	any orientation
Profile	Movable mounting clamps or T-slot nuts M5 in base channel
U-Magnet, removable	Mounting plate and screws from antimagnetical material
Rod	Threaded flange M18 x 1,5 or 3/4" -16 UNF-3A, Hex nut M18
Position magnet	Mounting plate and screws from antimagnetical material
Electrical connection	
Connection type	2 x 6 pin connector M16 or 2 x 5 pin connector M12 + 4 pin. connector M8
Input voltage	24 VDC (-15 / +20 %)
- Polarity protection	up to -30 VDC
- Overvoltage protection	up to 36 VDC
Current drain	90 mA typical
Ripple	< 1 % S-S
Electric strength	500 V (DC ground to machine ground)

Temposonics-RP+RH

Profibus

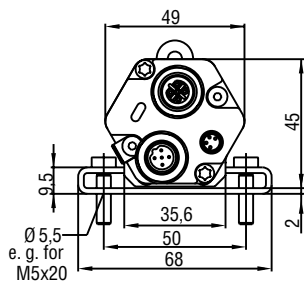

Connector outlet D53

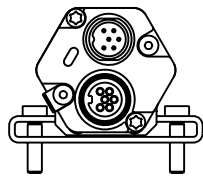

Connector outlet D63

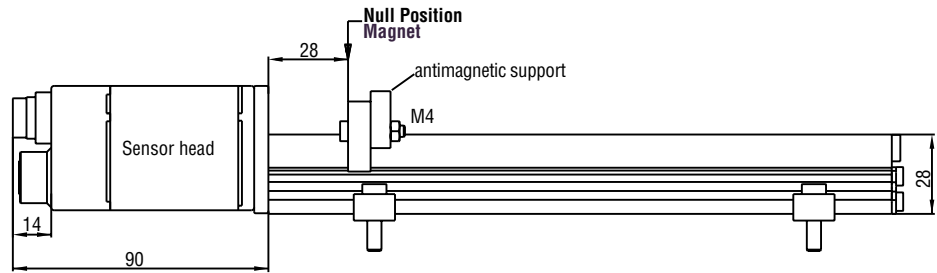
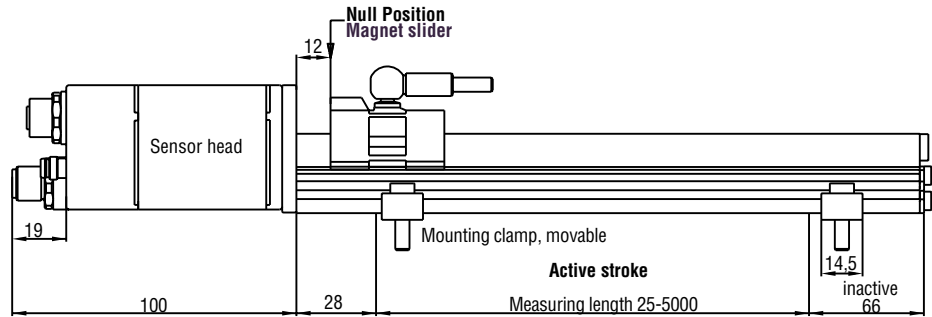

Selection of position magnets (upon delivery)

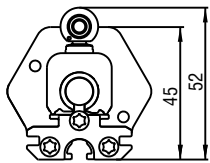

Magnet slider S
Part No. 252 182

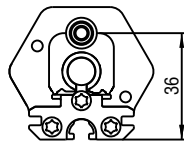

Magnet slider V
Part No. 252 184

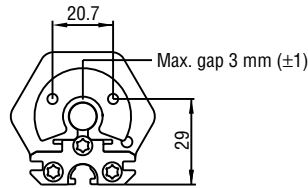

U-Magnet M OD33
Part No. 251 416-2

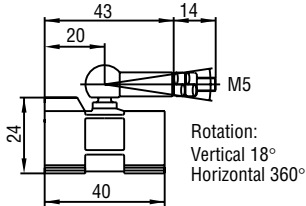

GFK, Magnet Hardferrite
Weigh ca. 30 g
Operating temperature:
-40 ... +75°C

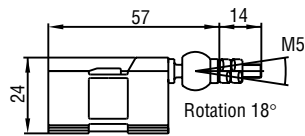

GFK, Magnet Hardferrite
Weigh ca. 30 g
Operating temperature:
-40 ... +75°C

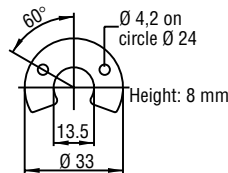

Composite PA-Ferrite-GF20
Weigh ca. 11g
Operating temperature:
-40 ... +100°C

Stable Profile Design

Temposonics-RP offers modular construction, flexible mounting configurations and easy installation. Position measurement is contactless via two versions of permanent magnets.

- A sliding magnet running in profile housing rails. Connection with the mobile machine part is via a ball jointed arm to taking up axial forces.
- A floating magnet, mounted directly on the moving machine part, travels over the profile at a low distance. Its air-gap allows the correction of small misalignments at installation.

Connection types

1. Connector outlet D63

- 6 pin male receptacle M16
- 6 pin female receptacle M16

2. Connector outlet D53

- 5 pin female receptacle M12
- 5 pin male receptacle M12
- 4 pin male receptacle M8

All measurements in mm

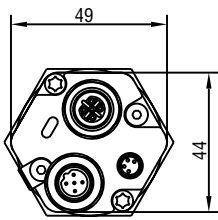

Connector outlet D53

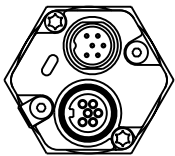
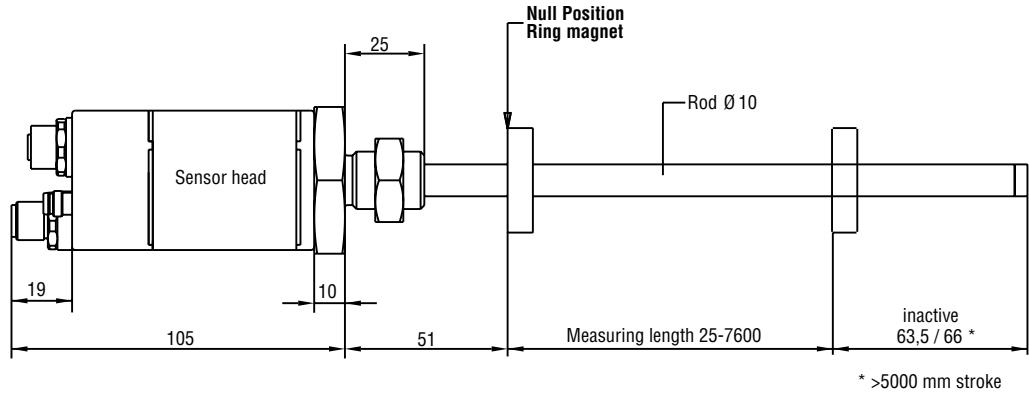

Connector outlet D63

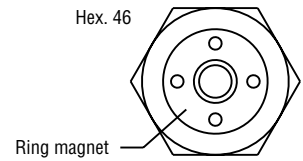
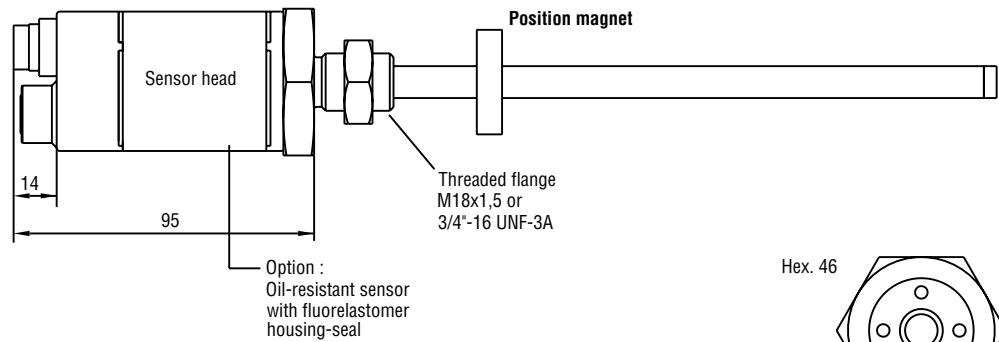

Hex. 46
Ring magnet

Selection of position magnets (not on delivery)

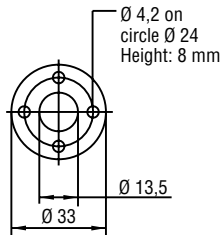

Ring magnet OD33
Part No. 201 542-2
Composite PA-Ferrite-GF20
Weigh ca. 14g
Operating temperature:
-40 ... +100°C

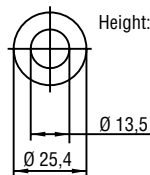

Ring magnet OD25,4
Part No. 400 533
Composite: PA-Ferrite
Weigh ca. 10g
Operating temperature:
-40 ... +100°C

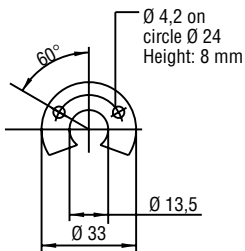

U-magnet M OD33
Part No. 251 416-2
Composite PA-Ferrite-GF20
Weigh ca. 11g
Operating temperature:
-40 ... +100°C

High Pressure Rod Design

Temposonics-RH with a pressure-resistant stainless steel flange and sensing rod is suitable for use in hydraulic cylinders and externally in all applications where space is a problem. Position measurement is via ring or U-magnets travelling along the sensing rod without any mechanical contact.

Advantage...
the completely operable sensor cartridge can be replaced for servicing easily without opening the fluid circuit.

Temposonics-RP+RH

Profibus

3 types of bus connection

1. Connector outlet D 63

Shielded hybrid cable for bus and input voltage

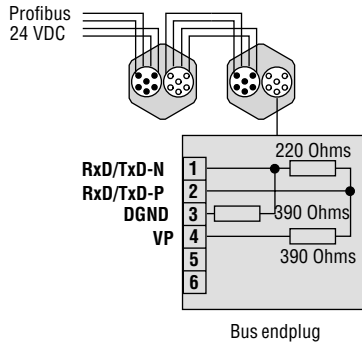

Wiring D63

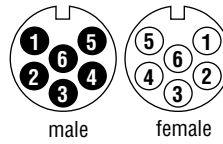

Male insert sensor plug
rear of cable connector

Pin	Cable	Function
1	green	RxD/TxD-N (Bus)
2	red	RxD/TxD-P (Bus)
3	---	DGND (Bus termination)
4	---	VP (Bus termination)
5	black	+24 VDC (-15 / +20 %)
6	blue	DC Ground (0V)
-	yellow/green	do not connect lly *female only

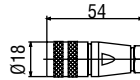

1) 6 pin female connector M16
Part No. ST C0 9131D06 PG9

2) 6 pin male connector M16
Part No. ST C0 9131H06 PG9

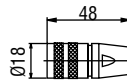

6 pin Bus endplug M16, male
Part No. ST A0 9131H06

2. Connector outlet D 53

Separate cable for bus and input voltage with Profibus connectors

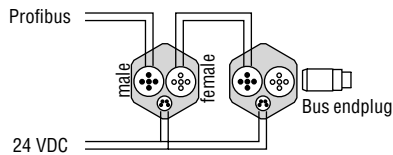

Wiring D53

Bus connector

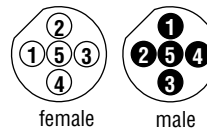

Inserts sensor plug
rear of cable connector

Pin	Cable	Function
1	---	VP+5 (Bus termination)
2	green	RxD/TxD-N (Bus)
3	---	DGND (Bus termination)
4	red	RxD/TxD-P (Bus)
5	shield	shield
		*female only

3. Variation of connector outlet with T-connector

Separate cables for bus and input voltage with Profibus connectors
No Bus breakdown at sensor disconnection

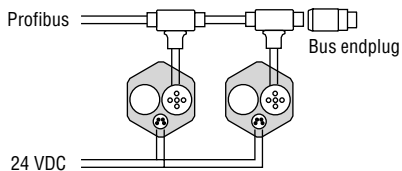

Input voltage

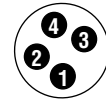

Male insert sensor plug
rear of cable connector

Pin	Cable	Function
1	brown	+24 VDC (-15/+20 %)
2	white	n.c.
3	blue	0 V (GND)
4	black	n.c.

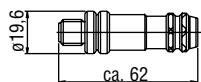

Part No. 560 884
5 pin Profibus
male connector M12

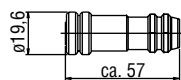

Part No. 560 885
5 pin Profibus
female connector M12

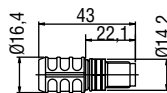

Part No. 560 888
5 pin Profibus
endplug M12

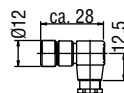

Part No. 560 886
4 pin connector M8
input voltage
insert adjustable
in 90°-positions

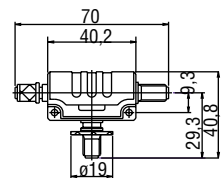

Part No. 560 887
5 pin Profibus
T-connector M12

Flexible installation in any position

Profile model

Normally, the sensor is firmly installed - fixed on a straight surface of the machine with movable mounting clamps or M5 screws in base channel - whilst the magnet is mounted at the mobile machine part.

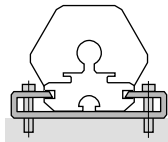

Mounting clamp with screws M5x20
Tightening torque: max. 5 Nm

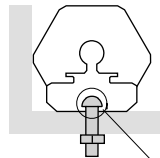

T-slot Nut in base channel

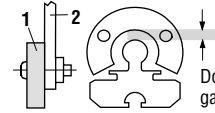
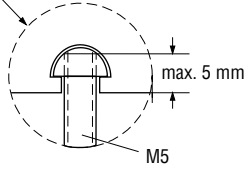

Do not exceed max. gap of 3 mm (± 1)

- 1 U-Magnet
- 2 Mounting plate and screws non-ferrous material

Rod model

Mount the sensor via flange thread or a hex nut. If possible, non-magnetizable material should be used for mounting support (dimensions as shown). With horizontal mounting, longer sensors (from 1 meter) must be provided with mechanical support.

Hydraulic sealing

Recommended is sealing of the flange facing with O-Ring (e.g. 22,4 x 2,65) in a cylinder cover nut or an O-Ring 15,3 x 2,2 in undercut.

Minimum assembly distance

1. Non-magnetizable material

2. Magnetizable material

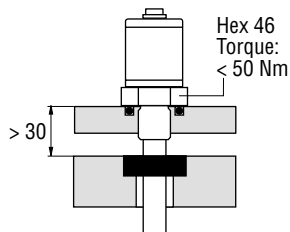

Recommended hydraulic sealing

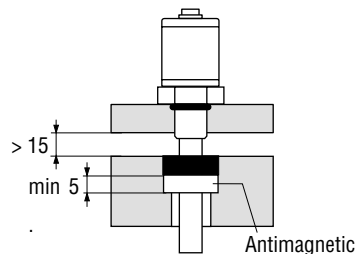

Alternative sealing O-Ring 15,3 x 2,2

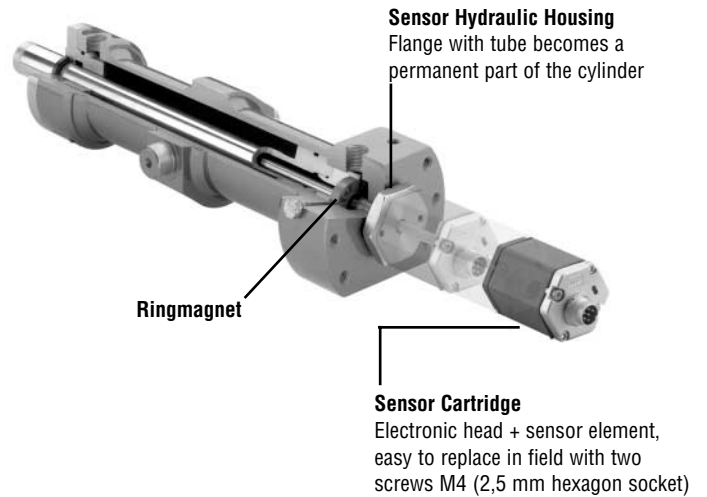

Cylinder installation

When used for direct stroke measurement in fluid cylinders, the sensor's high pressure, stainless steel rod installs into a bore in the piston head/rod assembly as illustrated. That guarantees a longlife and trouble-free operation - independent of used hydraulic fluid.

The sensor cartridge can be removed from the flange and rod housing while still installed in the cylinder. This procedure allows quick and easy sensor cartridge replacement, without the loss of hydraulic pressure.

Temposonics-RP+RH

Profibus

Temposonics

Sensor model

RP - Profile

RH - Rod

Form factor

Profile Temposonics-RP:

S - Magnet slider, joint at top

V - Magnet slider, joint at front

M - U-Magnet, OD33

Rod Temposonics-RH:

M - Flange M18 x 1,5 (Standard)

V - Flange M18 x 1,5

(Fluorelastomer housing-seal)

S - Flange 3/4" - 16 UNF - 3A

Measuring length

Profile - 0025...5000 mm

Rod - 0025...7600 mm

Standard: up to 1000 in 50 mm, greater 1000 in 250 mm steps

Other length upon request

Connection type

D63 - 2 x 6 pin male/female receptacle M16

D53 - 2 x 5 pin male/female receptacle M12, 4 pin male receptacle M8

Input voltage

1 - +24 VDC

Output

P = Profibus-DP

101 - Profibus-DP, Multi-Magnets measurement (max. 15 positions)

102 - Profibus-DP, 1-Magnet measurement (Standard)

103 - Profibus-DP, Position /speed measurement (max. 5 Positions/velocities)

Magnet number for Multi-Position measurement*

Z02 - Z15 = 2 - 15 pcs

* Note: Pls. specify magnet numbers for your sensing application and order separately

On delivery Profile Model: Sensor, magnet slider or U-magnet, 2 mounting clamps up to 1250 mm stroke + 1 clamp for every additional 500 mm

On delivery Rod Model: Sensor, hex nut, magnets must be ordered separately
Installation guide + CD-ROM (Electronic Data Sheet with standardized Device Data Base File)

Note: Projecting and parameterizing a Profibus system will be done with servicetool of Profibus mastersystem supplier.

Accessories (selection)

Magnet slider type »S«

Magnet slider type »V«

U-Magnet OD33, corresponding type »M«

Ring magnet OD33, Standard

Ring magnet OD25,4

O-Ring 15,3 x 2,2 Fluorelastomer FPM 75

Mounting clamp

T-slot nut M5 for base channel mounting

Connector outlet D63

6 pin M16 female cable connector

6 pin M16 male cable connector

6 pin M16 Bud-endplug, male

Bus hybrid cable (5 wires / 2x Bus power supply)

Part No.

252 182

252 184

251 416-2

201 542-2

400 533

401 133

400 802

401 602

STC 09131 D06 PG9

STC 09131 H06 PG9

STC 09131 H06

K 53 (specify length)

Accessories (selection)

Connector outlet D53

5 pin T-connector M12

5 pin Cable connector M12, male

5 pin Cable connector M12, female

5 pin Bus-endplug M12, male

4 pin 90° cable connector M8 female (power supply)

Profibus cable, 2 wires

MTS-Servicetools

Profibus Address Programmer

Connector outlet D63

Connector outlet D53

Profibus Mastersimulator for check-up sensor function

Cable Mastersimulator - Sensors, connector outlet D63

Cable Mastersimulator - Sensors, connector outlet D53

Profibus 24V EMC Bud-input box

Part No.

560 887

560 884

560 885

560 888

560 886

K 58 (specify length)

252 173-D63

252 173-D53

401 727

401 726

252 383

252 916

www.mtssensor.de

www.temposonics-shop.de

Service Hotline: 01805 - mtssensor

© MTS Temposonics® R-Series Temposonics RPRH Profibus 20102005e - Alterations reserved

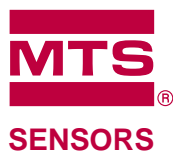

Germany

MTS Sensor Technologie
GmbH & Co. KG
Auf dem Schüffel 9
D-58513 Lüdenscheid
Tel.: +49-2351-9587-0
Fax: +49-2351-56491
info@mtssensor.de
www.mtssensor.de

USA

MTS Systems Corporation
Sensors Division
3001 Sheldon Drive
Cary, NC 27513, USA
Tel.: +1-919-677-0100
Fax: +1-919-677-0200
info@mtssensors.com
www.mtssensors.com

Japan

MTS Sensors Technology Corp.
Ushikubo Bldg.
737 Aihara-cho, Machida-shi
Tokyo 194-0211, Japan
Tel.: +81-42-775-3838
Fax: +81-42-775-5516
info@mtssensor.co.jp
www.mtssensor.co.jp